

Received  
OCT 25 2019  
City of Grove City



NO.	DATE	ISSUE / REVISIONS
1	2019.10.22	REV. SPECIAL USE PERMIT
0	2019.10.01	SPECIAL USE PERMIT SUB.
		COMMENTS
		BY
		CHK

EXISTING/DEMO PLAN  
#714 GROVE CITY, OHIO  
1910 STRINGTOWN ROAD, GROVE CITY, OH 43123

Larson Design Group • Architects Engineers Surveyors  
1000 Commerce Park Drive • Suite 201  
Williamsport, PA 17701  
PHONE 570.323.6603 TOLL FREE 877.323.6603  
FAX 570.323.9902 • www.larsondesigngroup.com

EG AMERICA LLC  
302 2. 3RD ST. FLR 3  
CINCINNATI, OH 45202  
PHONE Client phone

SHEET NO: C10  
PROJECT NO: 12322-001

**LEGEND**

FEATURES TEXT	EXISTING	Feature text
PROPERTY LINE	---	---
RIGHT-OF-WAY LINE	---	---
EASEMENT LINE	---	---
CONTOUR LINE	---	100
BUILDING SETBACK	---	---
BUILDING LINE	---	---
FENCE LINE	---	x
EDGE OF PAVEMENT	---	---
GRAVEL	---	---
CONCRETE CURB	---	---
CONCRETE/SIDEWALK	---	---
SIGN	---	---
BENCHMARK	---	---
DRAINAGE LINE, MANHOLE & CB	---	MH
OVERHEAD UTILITIES & POLE	---	---

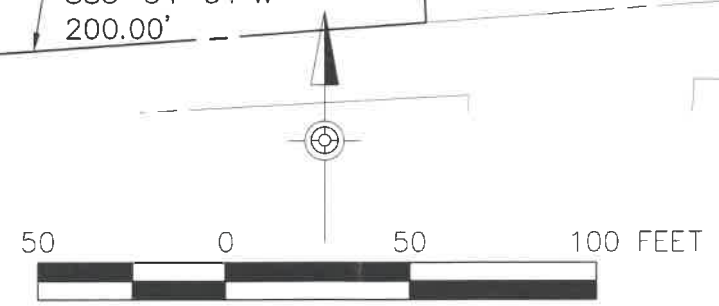
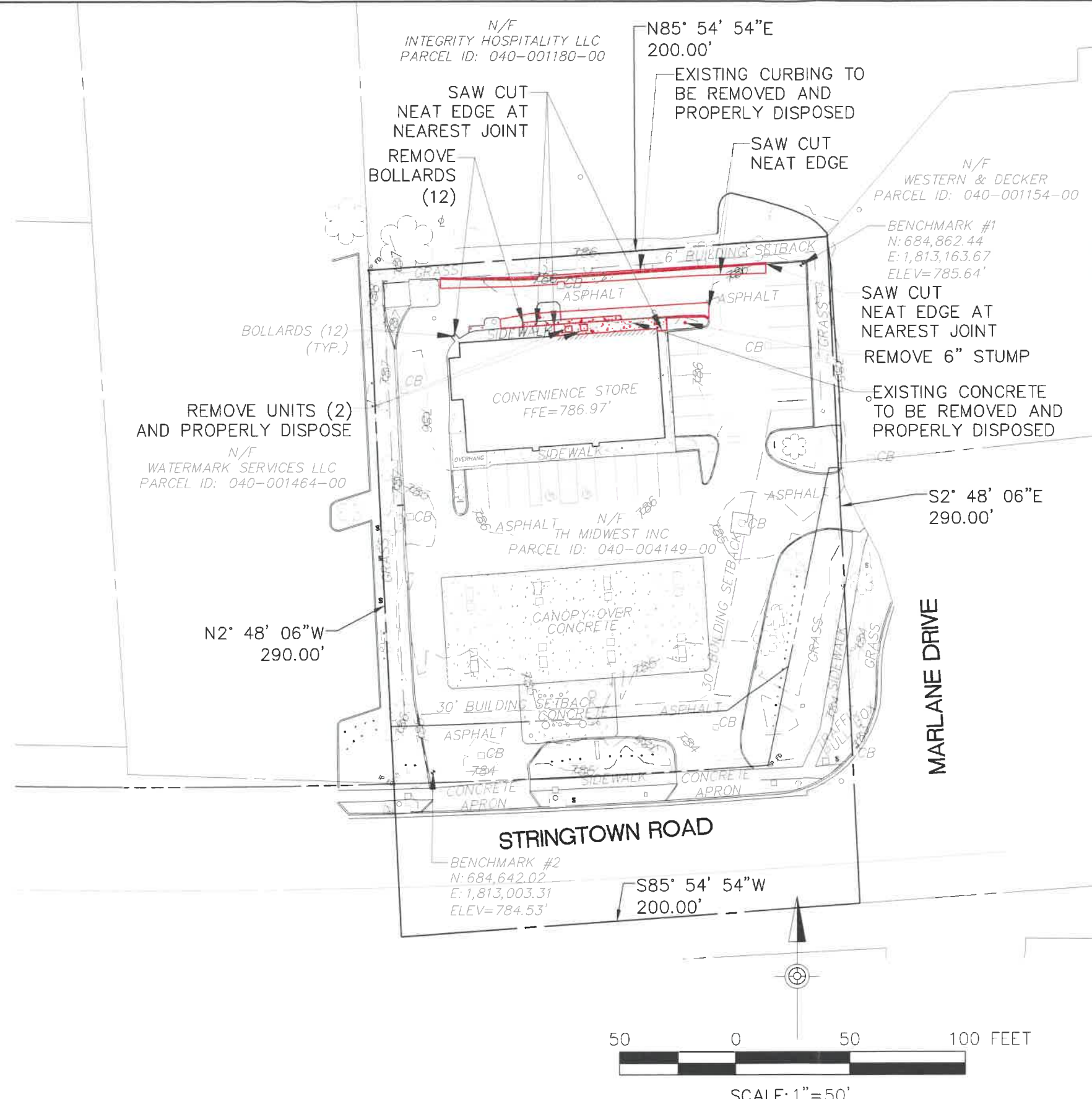

It is a violation of the law for any person, unless acting under the direction of a licensed Architect, Engineer or Land Surveyor, to alter an item in any way. Plans, maps, specifications, studies, and reports not containing a red ink seal imprint on the cover sheet accompanied by an original signature by the licensed professional may have been fraudulently altered and shall not be considered an original copy. Copyright Protected 2019, Larson Design Group.

N/A  
 INTEGRITY HOSPITALITY LLC  
 PARCEL ID: 040-001180-00

NEW TRASH ENCLOSURE DOORS;  
 (TRASH ENCLOSURE TO MATCH COLOR OF BUILDING)

UNITS TO BE RELOCATED AS NEEDED TO FIT DRIVE-THRU MENU BOARD AND ORDER CONFIRMATION UNIT  
 DRIVE-THRU WINDOW  
 PAINTED 4" WHITE LINE STRIPE

N/A  
 WATERMARK SERVICES LLC  
 PARCEL ID: 040-001404-00

DO NOT ENTER DRIVE-THRU SIGN (OPTIONAL)

MENU BOARD  
 NEW CURB (142 LF)  
 TIE TO EXISTING  
 7.3'  
 ORDER CONFIRMATION UNIT  
 BYPASS LANE  
 8.1'  
 NEW CURB (90 LF)  
 NEW PAVE (TYP.)

N/A  
 WESTERN & DECKER  
 PARCEL ID: 040-001154-00

BENCHMARK #1  
 N: 684,862.44  
 E: 1,813,163.67  
 ELEV=785.64'

PAINTED WHITE DIRECTIONAL ARROW (TYP.)  
 CLEARANCE SIGN

DRIVE-THRU DIRECTIONAL SIGN

CONVENIENCE STORE  
 FFE=786.97'  
 PREVIEW BOARD  
 LANDSCAPED AREA

N/A  
 TH MIDWEST INC  
 PARCEL ID: 040-004149-00

DO NOT ENTER DRIVE-THRU SIGN  
 CANOPY OVER CONCRETE

MARLANE DRIVE

STRINGTOWN ROAD

BENCHMARK #2  
 N: 584,642.02  
 E: 1,813,083.51  
 ELEV=784.53'

N/A  
 FMHO MARKETING CO  
 PARCEL ID: 040-004537-00

N/A  
 WAFFLE HOUSE INC  
 PARCEL ID: 040-004539-00

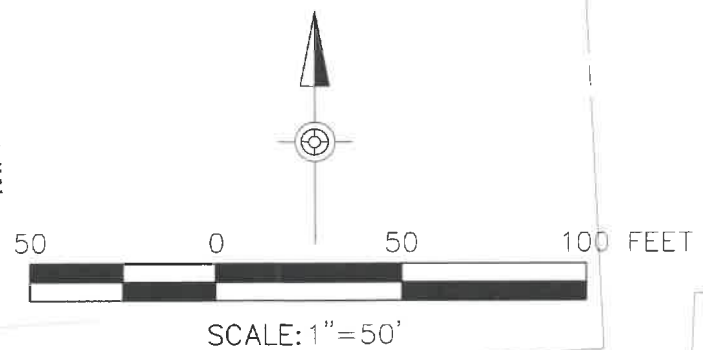

NO	DATE	COMMENTS	ISSUE	REVISIONS
1	2019.10.22	REV. SPECIAL USE PERMIT	JWH	CMS
0	2019.10.01	SPECIAL USE PERMIT SUB.	JWH	CMS
				BY CHK

**SITE LAYOUT PLAN**  
**#714 GROVE CITY, OHIO**  
 1910 STRINGTOWN ROAD, GROVE CITY, OH 43123

Larson Design Group • Architects Engineers Surveyors  
 1000 Commerce Park Drive • Suite 201  
 Williamsport, PA 17701  
 PHONE 570.323.6603 TOLL FREE 877.323.6603  
 FAX 570.323.9902 • www.larsondesigngroup.com

EG AMERICA LLC  
 302 2. 3RD ST. FLR 3  
 CINCINNATI, OH 45202  
 PHONE Client phone

It is a violation of the law for any person, unless acting under the direction of a licensed Architect, Engineer or Land Surveyor, to alter an item in any way. Plans, maps, specifications, studies, and reports not containing a red ink seal imprint on the cover sheet accompanied by an original signature by the licensed professional may have been fraudulently altered and shall not be considered an original copy. Copyright Protected 2019, Larson Design Group.

SHEET NO: **C20**  
 PROJECT NO: 12322-001

**LEGEND**

- ◻ BM – BABY GEM BOXWOOD  
BUXUS MICROPHYLLA VAR.  
JAPONICA 'GREGEM'  
MINIMUM HEIGHT OF 24" AT  
TIME OF INSTALLATION
- \* HS – STELLA DE ORO DAYLILY  
HEMEROCALLIS X 'STELLA DE ORO'  
1 GALLON CONTAINER
- ⊗ GP – GIRARDS PLEASANT WHITE  
AXALEA – AZALEA X 'GIRARD'S  
PLEASANT WHITE'  
MINIMUM HEIGHT OF 24" AT TIME  
OF INSTALLATION

N/F  
WATERMARK SERVICES LLC  
PARCEL ID: 040-001464-00

N/F  
INTEGRITY HOSPITALITY LLC  
PARCEL ID: 040-001180-00

N/F  
WESTERN & DECKER  
PARCEL ID: 040-001154-00

BENCHMARK #1  
N: 884,862.44  
E: 1,513,763.67  
ELEV=785.64'

N/F  
TH MIDWEST INC  
PARCEL ID: 040-004149-00

BENCHMARK #2  
N: 884,642.02  
E: 1,513,003.37  
ELEV=784.53'

N/F  
EMRO MARKETING LLC  
PARCEL ID: 040-004537-00

N/F  
WAFFLE HOUSE INC  
PARCEL ID: 040-004538-00



MARLANE DRIVE

STRINGTOWN ROAD

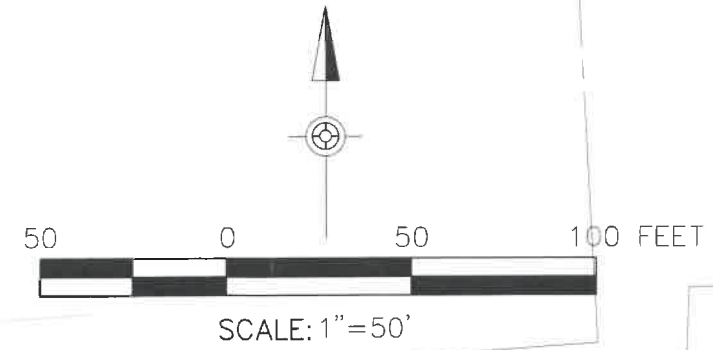

It is a violation of the law for any person, unless acting under the direction of a licensed Architect, Engineer or Land Surveyor, to alter an item in any way. Plans, maps, specifications, studies, and reports not containing a red ink seal imprint on the cover sheet accompanied by an original signature by the licensed professional may have been fraudulently altered and shall not be considered an original copy. Copyright Protected 2019, Larson Design Group.



NO	DATE	COMMENTS	BY	CHK
1	2019.10.22	REV. SPECIAL USE PERMIT	JWH	CMS
0	2019.10.01	SPECIAL USE PERMIT SUB.	JWH	CMS

ISSUE / REVISIONS

SITE GRADING / LANDSCAPE PLAN  
#714 GROVE CITY, OHIO  
1910 STRINGTOWN ROAD, GROVE CITY, OH 43123

Larson Design Group • Architects Engineers Surveyors  
1000 Commerce Park Drive • Suite 201  
Williamsport, PA 17701  
PHONE 570.323.6603 TOLL FREE 877.323.6603  
FAX 570.323.9902 • www.larsondesigngroup.com

EG AMERICA LLC  
302 2<sup>ND</sup> 3RD ST. FLR 3  
CINCINNATI, OH 45202  
PHONE Client phone

SHEET NO: C21  
PROJECT NO: 12322-001

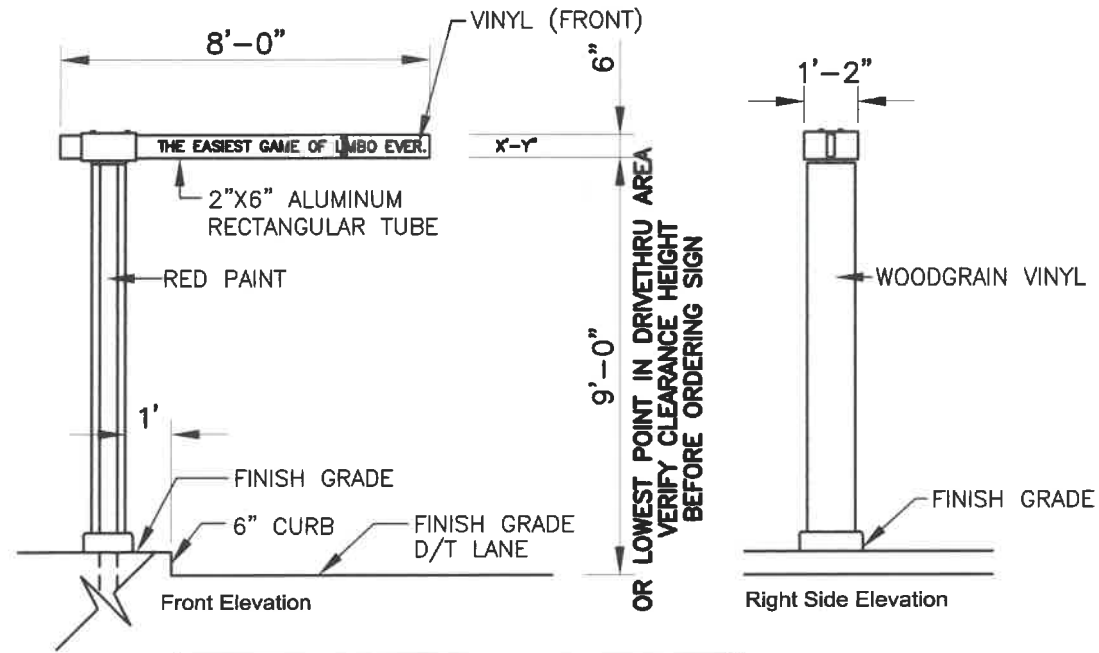

NOTE:  
SIGN STRUCTURAL FOUNDATION AS REQUIRED BY SITE CONDITIONS. DESIGN IS THE RESPONSIBILITY OF THE SUBCONTRACTOR.

**DRIVE-THRU CLEARANCE SIGN 2020 STANDARD IMAGE**  
SCALE: NOT TO SCALE

**SIGN INSTALLER RESPONSIBILITIES:**

1. PROVIDE ALL DRAWINGS NECESSARY FOR SIGN PERMITS.
2. APPLY FOR, OBTAIN, AND PAY FOR ALL REQUIRED SIGN PERMITS.
3. COORDINATE EXCAVATION OF SIGN FOUNDATIONS WITH G.C.
4. SET ANCHOR BOLTS OR BASE PLATES AS REQUIRED.
5. COMPLETE SIGN INSTALLATION.
6. REMOVE EXCESS DEBRIS, ROUGH GRADE AREA FOR LANDSCAPING.

**GENERAL CONTRACTOR RESPONSIBILITIES:**

1. COORDINATE EXCAVATION OF SIGN FOUNDATIONS WITH SIGN SUPPLIER.
2. PROVIDE POWER TO ALL SIGN LOCATIONS AS REQUIRED.
3. MAKE FINAL ELECTRICAL CONNECTIONS TO EACH SIGN.

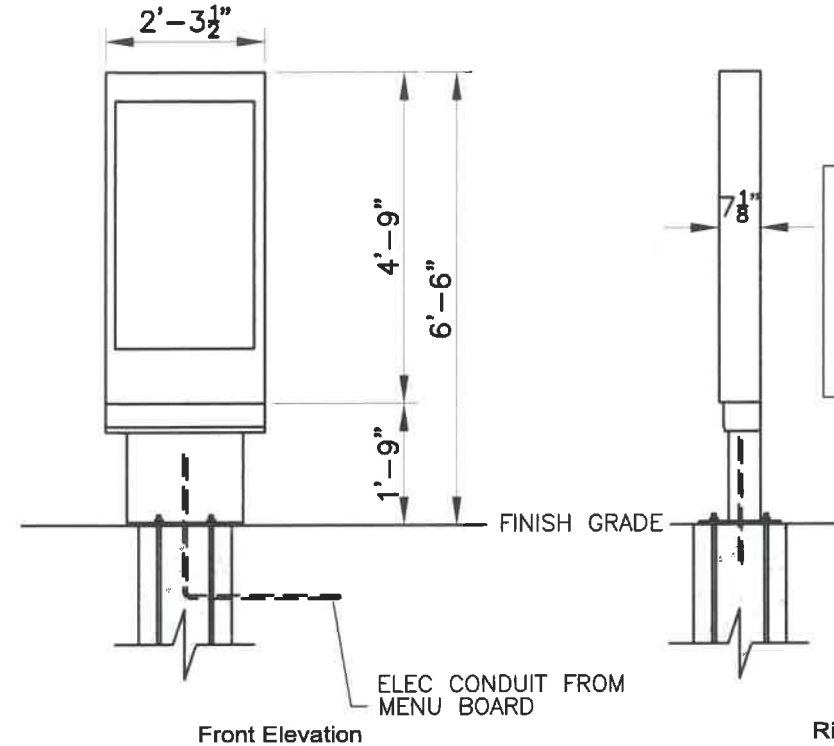

SIGN STRUCTURAL FOUNDATION BASE AS REQ'D BY SITE CONDITIONS. DESIGN IS THE RESPONSIBILITY OF THE SUBCONTRACTOR. (MIN. 16" DIAMETER, 5'-0" DEEP)

**OPTIONAL PREVIEW BOARD**  
SCALE: NOT TO SCALE

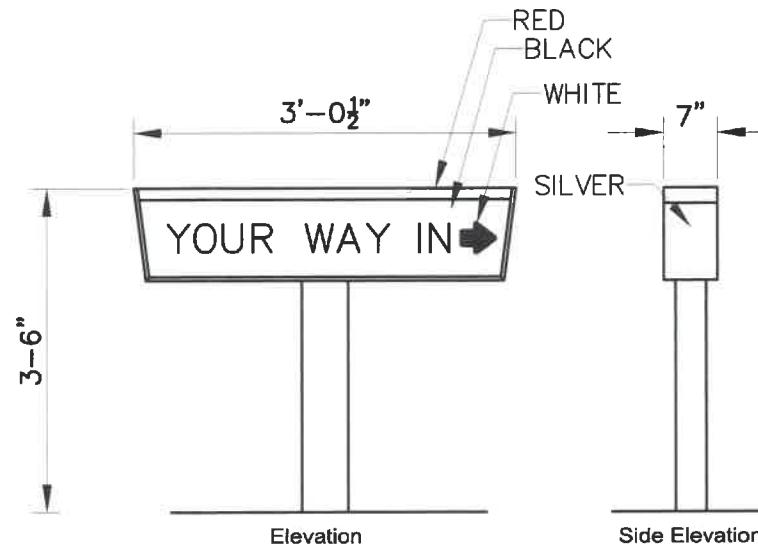

NOTE:  
SIGN STRUCTURAL FOUNDATION AS REQ'D BY SITE CONDITIONS. DESIGN IS THE RESPONSIBILITY OF THE SUBCONTRACTOR.

**DIRECTIONAL SIGN 2020 IMAGE**  
SCALE: NOT TO SCALE

It is a violation of the law for any person, unless acting under the direction of a licensed Architect, Engineer or Land Surveyor, to alter an item in any way. Plans, maps, specifications, studies, and reports not containing a red ink seal imprint on the cover sheet accompanied by an original signature by the licensed professional may have been fraudulently altered and shall not be considered an original copy. Copyright Protected 2019, Larson Design Group.



NO.	DATE	COMMENTS	BY	CHK
1	2019.10.22	REV. SPECIAL USE PERMIT	JWH	CMS
0	2019.10.01	SPECIAL USE PERMIT SUB.	JWH	CMS

**DETAILS**  
**#714 GROVE CITY, OHIO**  
1910 STRINGTOWN ROAD, GROVE CITY, OH 43123  
Larson Design Group • Architects Engineers Surveyors  
1000 Commerce Park Drive • Suite 201  
Williamsport, PA 17701  
PHONE 570.323.6603 TOLL FREE 877.323.6603  
FAX 570.323.9902 • www.larsondesigngroup.com  
**EG AMERICA LLC**  
302 2. JRD ST. FLR 3  
CINCINNATI, OH 45202  
PHONE Client phone

SHEET NO.: **3.0**  
PROJECT NO.: 12322-001

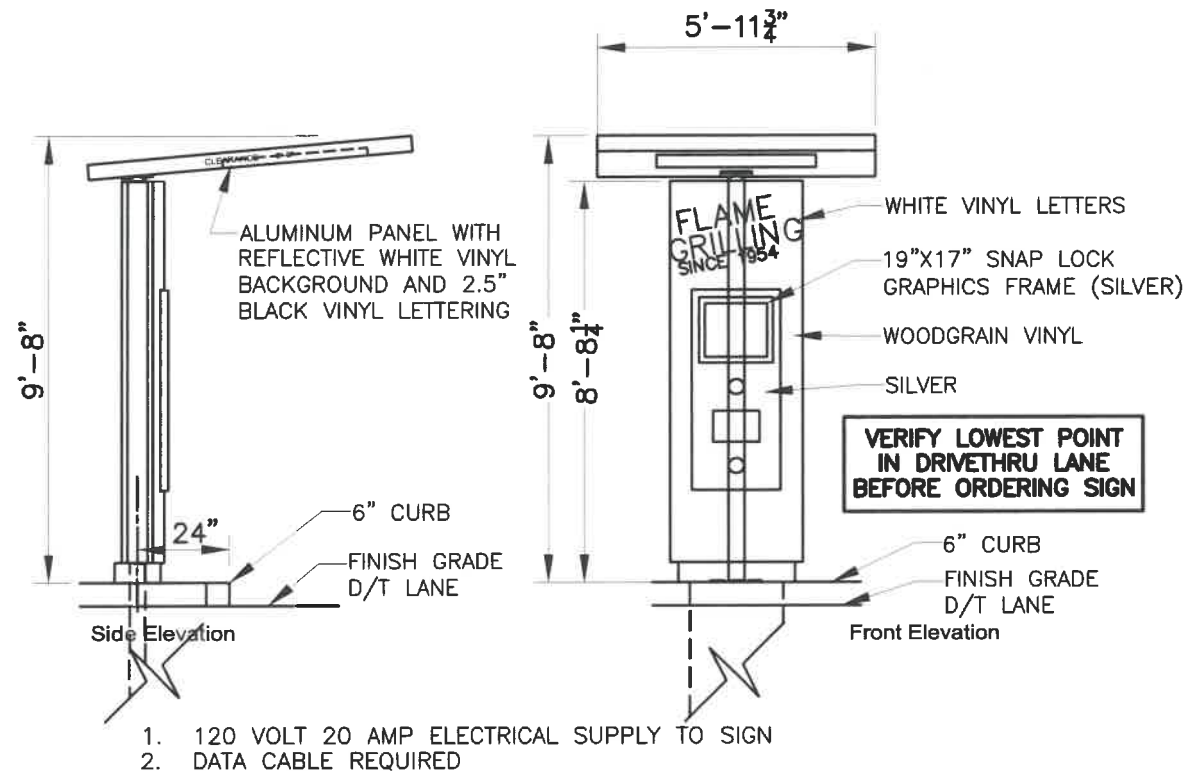
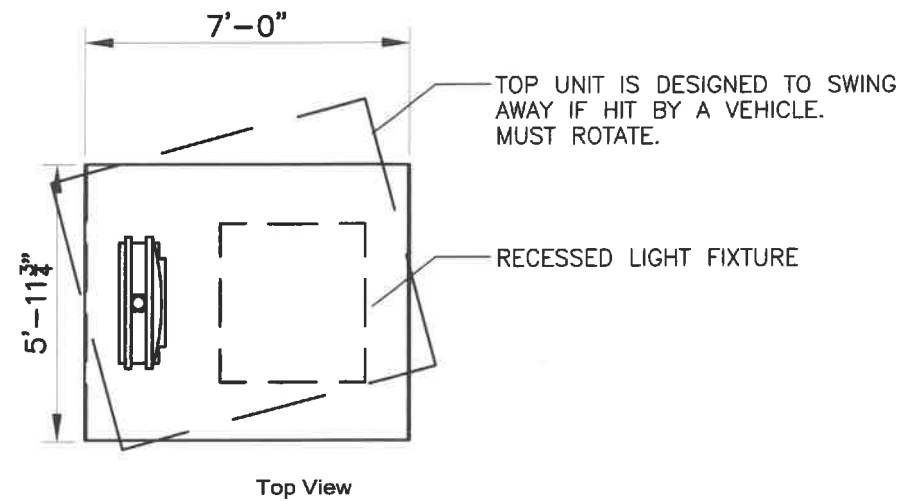

**NOTE:**  
SIGN STRUCTURAL FOUNDATION AS REQUIRED BY SITE CONDITIONS. DESIGN IS THE RESPONSIBILITY OF THE SUBCONTRACTOR.

**ORDER CONFIRMATION UNIT**  
SCALE: NOT TO SCALE

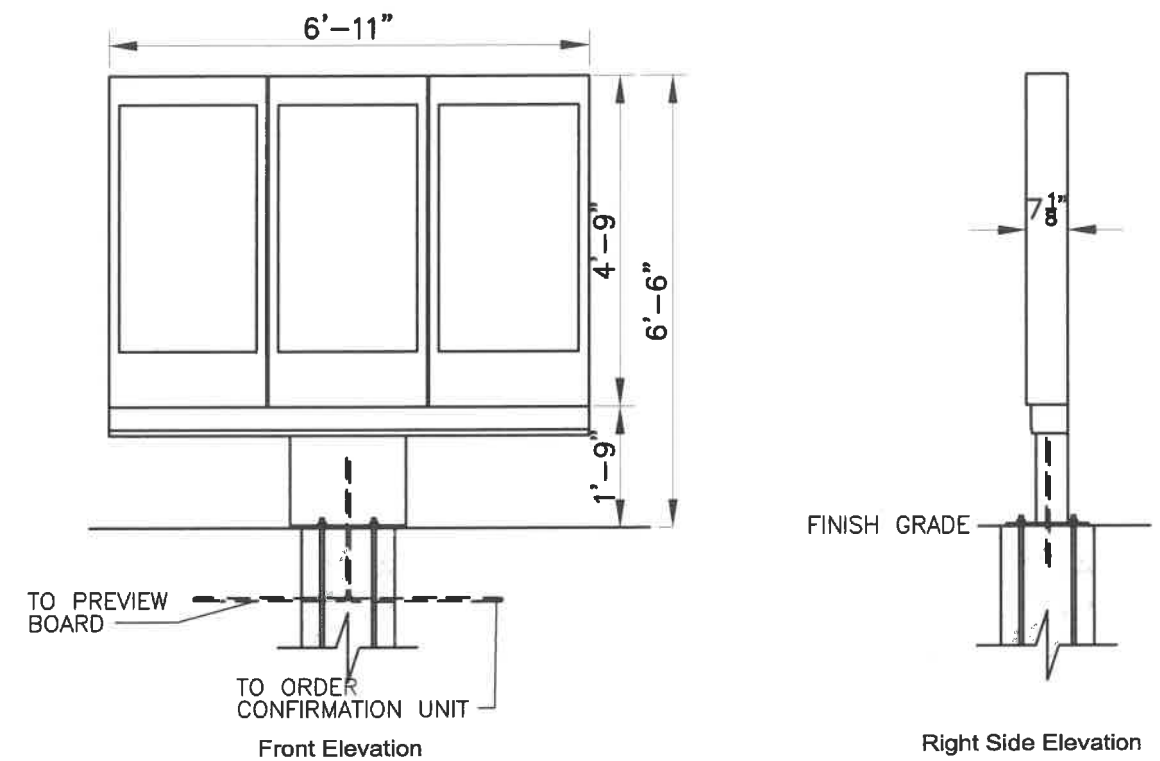

**MENUBOARD ELEVATIONS**  
SCALE: NOT TO SCALE

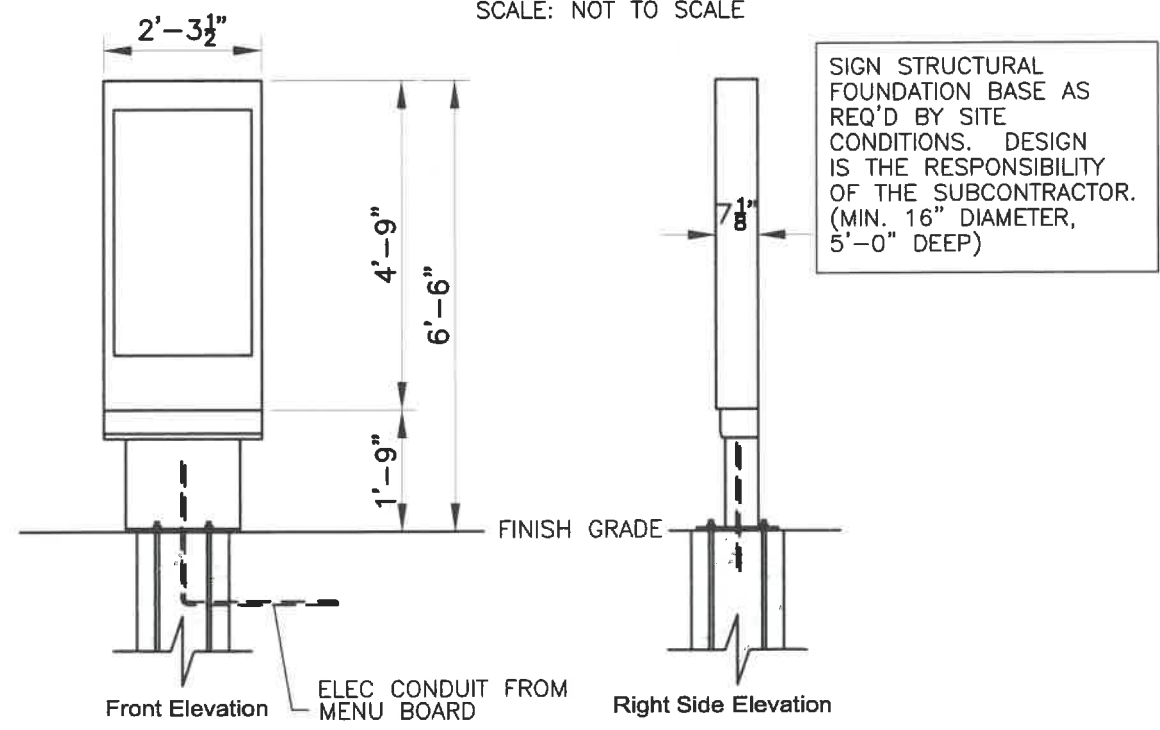

**OPTIONAL PREVIEW BOARD ELEVATIONS**  
SCALE: NOT TO SCALE

SIGN STRUCTURAL FOUNDATION BASE AS REQ'D BY SITE CONDITIONS. DESIGN IS THE RESPONSIBILITY OF THE SUBCONTRACTOR. (MIN. 16" DIAMETER, 5'-0" DEEP)

It is a violation of the law for any person, unless acting under the direction of a licensed Architect, Engineer or Land Surveyor, to alter an item in any way. Plans, maps, specifications, studies, and reports not containing a red ink seal imprint on the cover sheet accompanied by an original signature by the licensed professional may have been fraudulently altered and shall not be considered an original copy. Copyright Protected 2019, Larson Design Group.



NO.	DATE	COMMENTS	ISSUE	REVISIONS
1	2019.10.22	REV. SPECIAL USE PERMIT	JWH	CMS
0	2019.10.01	SPECIAL USE PERMIT SUB.	JWH	CMS

**DETAILS**

**#714 GROVE CITY, OHIO**  
1910 STRINGTOWN ROAD, GROVE CITY, OH 43123

**EG AMERICA LLC**  
302 2. JRD ST. FLR 3  
CINCINNATI, OH 45202  
PHONE Client phone

Larson Design Group • Architects Engineers Surveyors  
1000 Commerce Park Drive • Suite 201  
Williamsport, PA 17701  
PHONE 570.323.6603 TOLL FREE 877.323.6603  
FAX 570.323.9902 • www.larsondesigngroup.com

SHEET NO.: **C31**

PROJECT NO.: 12322-001